

AKO-145601

Electronic expansion valve controller

User Manual



Index	Page
1.- Introduction	3
2.- Versions and references	3
Compatibility.....	3
3.- Installation	4
Precautions	4
Maintenance	4
Emergency power supply input	4
Initial configuration	4
Wiring.....	5
4.- Equipment description.....	7
Indicators.....	7
Messages.....	7
5.-Operation.....	8
Keypad.....	8
Display.....	8
Adjustment of parameters	8
Regulation	9
Alarms	10
Pressure Probe	10
Temperature probe	10
Expansion valve.....	10
Initial parameters	11
6.- Table of parameters.....	11
7.- Technical specifications.....	13

AKO Electromecánica thanks and congratulates you for purchasing our product, in whose development and manufacture the most innovative technology has been used, as well as strict production and quality control processes.

Our commitment to satisfy our customers and our continuous efforts to improve every day can be seen in the various quality certifications we have obtained. This is a high performance, high technology product. The operation and final performance of the equipment depend on proper planning, installation, configuration and commissioning. Read this manual carefully before installation, and always follow its instructions. Only qualified personnel should install or perform technical assistance on this product.

This product is designed to be used in the applications described in the product manual. AKO Electromecánica gives no guarantee of its operation in any use not foreseen in the manual, and is not responsible for any damage resulting from improper use, configuration, installation or commissioning.

It is the responsibility of the installer and the customer to comply with and ensure others comply with all regulations applicable to installations incorporating our products. AKO Electromecánica is not responsible for any damage caused by non-compliance with regulations. Follow strictly the instructions given in this manual.

To maximise the service life of our equipment, these recommendations should be followed:

- Do not expose electronic equipment to dust, dirt, water, rain, humidity, high temperatures, chemicals or corrosive substances of any sort.

- Do not submit the equipment to blows or vibrations nor try to manipulate it differently from shown in the manual.

- Never exceed the specifications and limitations indicated in the manual.

- Always respect the specified ambient working and storage conditions.

- During and after installation, avoid leaving loose, broken, unprotected or damaged wiring, since they might constitute a risk for the equipment and its users.

AKO Electromecánica reserves the right to make any non-metrology modification to the documentation or the equipment without previous notice.

1.- Introduction

Electronic expansion valves controller for refrigeration systems, compatible with most electronic expansion valves on the market. Its innovative PID algorithm allows you to optimise the evaporator overheating control and, as a result, improve the efficiency of the refrigeration system.

It is equipped with MODBUS communications for remote monitoring and parametrisation.

2.- Versions and references

MODEL	DESCRIPTION
AKO-14560	Electronic expansion valves control kit consisting of: -Controller AKO-145601 -Pressure probe AKO-15571 -Temperature probe AKO-15606 -Power supply transformer 115 - 230 V / 24 V AKO-80077
AKO-145601	Spare EEV electronic controller
AKO-15571	Spare pressure probe from -1 to 15 bar
AKO-15572	Optional pressure probe from -1 to 25 bar
AKO-15606	Spare Pt1000 Temperature probe (-100 to 120 °C)
AKO-80077	Spare power supply transformer 115 - 230 V / 24 V

Compatibility

The following tables show controller **AKO-145601** compatibility with electronic expansion valves and refrigerant gases.

COMPATIBLE ELECTRONIC EXPANSION VALVES				
Manufacturer	DANFOSS	ALCO	SPORLAN	CAREL
Models	ETS 12.5	EX4	SEI 0.5~11	
	ETS 25B	EX5	SEI 1.5~20	
	ETS 50B	EX6	SEI 30	E2V
	ETS 100B	EX7	SEI 100	
	ETS 250	EX8	SEI 175	
	ETS 400			

COMPATIBLE REFRIGERANT GASES						
R-22	R-134A	R-404A	R-407C	R-410A	R-717	R-23
R-507C	HFO 1234ze	R-744	R-407A	R-407F	R-507A	R-245F

3.- Installation

Precautions

Using the unit not observing the manufacturer's instructions may alter the appliance's safety requirements. Only probes supplied by AKO should be used for the appliance to operate correctly.

The unit should be installed in a place protected from vibrations, water and corrosive gases, where the ambient temperature does not exceed the values indicated in the technical data.

For the reading to be correct, the probe should be used in a place without heat influences apart from the temperature you want to measure or control.

The probe and its cable should **NEVER** be installed in a conduit together with power supply, control or feeder cables.

The power supply circuit should be equipped with a switch for its disconnection of at least 2A, 230V, situated near the appliance. The cables are inserted into the rear part and should be H05VV-F or H05V-K type. The section to be used will depend on local regulations, but should not under any circumstances be less than 1 mm².

The cables for wiring the relay contacts should have a section of between 1 mm² and 2.5 mm² and wire for the one in common should always have a section of 2.5 mm². Using of halogen-free cables is recommended.

Probes 1 and 2 should be installed as close as possible to the evaporator output. There should not be any device between them (valves, peep-holes etc.) that could alter the reading.

Maintenance

Clean the surface of the controller with a soft cloth, water and soap. Do not use abrasive detergents, petrol, alcohol or solvents.

Emergency power supply input

If the controller has an emergency power supply (12 Vdc), this closes the expansion valve, and displays the **CL E** message in the event of a fault in the electricity supply.

Initial configuration

This equipment has been designed to regulate the electronic expansion valve via overheating control of the refrigerant gas in the evaporator. Its configuration has been set, by default, for the most common applications. Check that the parameters match the characteristics of its installation.

Prior to start-up, it is vital to configure the following parameters:

rFE: Select the type of refrigerant gas used in the installation from among the following compatible gases:

- | | | | | | |
|--------------------|-------------------|------------------------|-------------------|--------------------|--------------------|
| 0 : R-22 | 1 : R-134A | 2 : R-404A | 3 : R-407C | 4 : R-410A | 5 : R-717 |
| 6 : R-23 | 7 : R-507C | 8 : R-HFO1234ze | 9 : R-744 | 10 : R-407A | 11 : R-407F |
| 12 : R-507A | 13 : R245F | | | | |

Eñ: Select the expansion valve model installed from among the following compatible models:

- | | | | |
|-----------------------------------|-------------------------------------|-------------------------------------|--------------------------------|
| 1 : Danfoss ETS 12.5 / 25B | 2 : Danfoss ETS 50B | 3 : Danfoss ETS 100B | 4 : Danfoss ETS 250 |
| 5 : Danfoss ETS 400 | 6 : Alco EX4 | 7 : Alco EX5 | 8 : Alco Ex6 |
| 9 : Alco EX7 | 10 : Alco EX8 (330 step/sec) | 11 : Alco EX8 (500 step/sec) | 12 : Sporlan SEI 0.5~11 |
| 13 : Sporlan SEI 1.5~20 | 14 : Sporlan SEI 30 | 15 : Sporlan SEI 100 | 16 : Sporlan SEI 175 |
| 17 : Carel E2V | | | |

SH: Configure the overheating set point

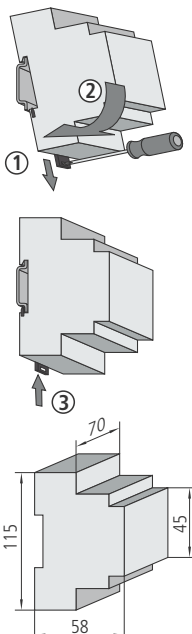

Wiring

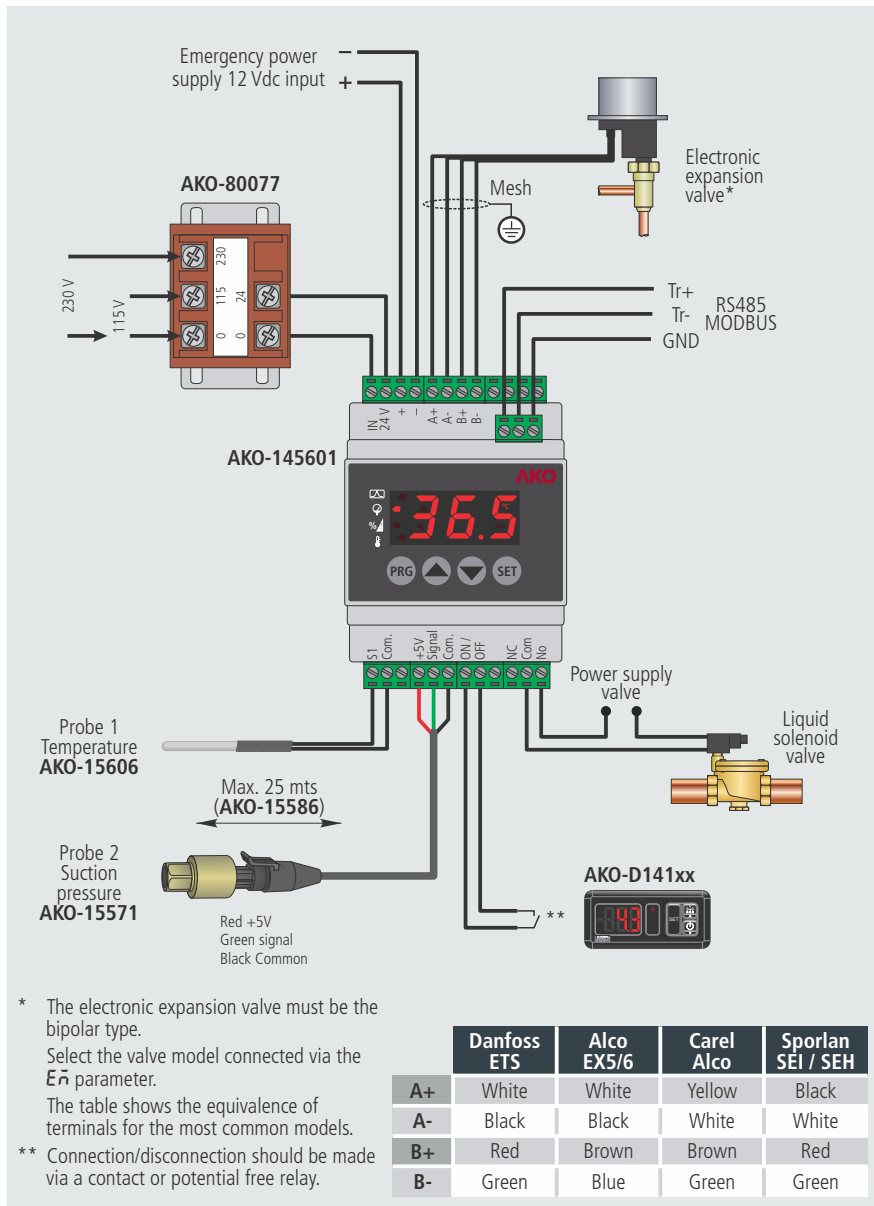

Connectivity

The controllers are equipped with a port for connection of RS485 (MODBUS) data, which allows for remote management of these using an **AKO-5012** web-server.

The MODBUS address is set with the **E Id** parameter. The default value is 1. This address must be different for each unit within the same network.



IMPORTANT: AKO-14560 controllers can only share a MODBUS network with other **AKO-14560** devices. The rest of AKO devices must be connected to an independent network.

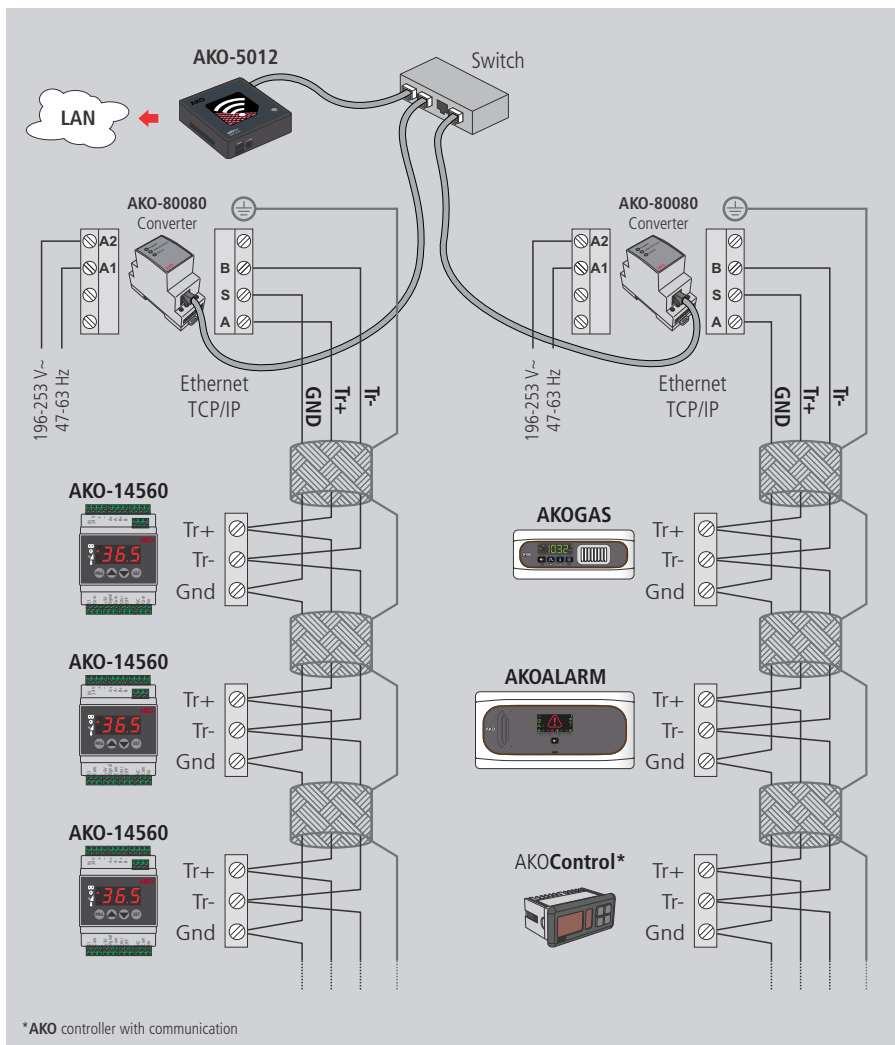

*AKO controller with communication

4.- Equipment description

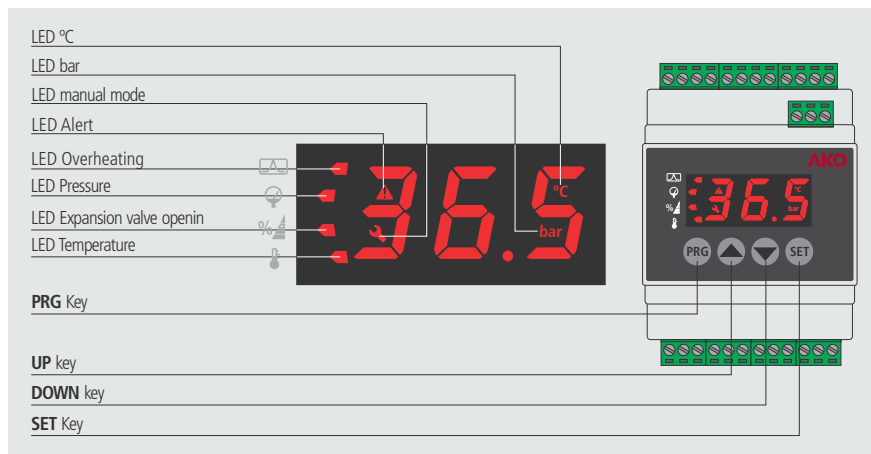

Indicators

LED °C: Indicates that the display shows the temperature value in °C.

LED bar: Indicates that the display shows the pressure value in bars.

LED manual mode: Indicates that the opening amount of the valve has been configured manually (**Ear** parameter).

LED Alert: Indicates that there is an active alert.

LED Overheating: Indicates that the display shows the overheating value.

LED Pressure: Indicates that the display shows the suction pressure value (Probe 2).

LED Expansion valve opening: Indicates that the display shows the valve opening percentage.

LED Temperature: Indicates that the display shows the temperature value.

Messages

Message	Description
<i>PS</i>	Problem in the pressure sensor
<i>ESd</i>	Probe 1 not connected
<i>ESC</i>	Crossed temperature probe
<i>ñoP</i>	Maximum Operation Pressure (MOP) alarm
<i>LoP</i>	Lower Operation Pressure (LOP) alarm
<i>hS</i>	Maximum overheating alarm
<i>LS</i>	Lower overheating alarm
<i>F-R</i>	Frost detection alarm
<i>StP</i>	Regulation stopped by external thermostat (ON/OFF Input)
<i>ERL</i>	Expansion valve initialisation
<i>ELE</i>	Valve closing underway due to fault in the electricity supply (emergency power supply required)



IMPORTANT: In the event of an alarm or fault in any of the probes, the controller closes the liquid solenoid and expansion valve until the problem is solved.

5.- Operation

Keypad

PRG key: Pressing it for 5 seconds accesses the parameters programming menu.

Pressing it twice allows the regulation to be restarted in the event of an alarm (see page 10).

In the programming menu, you may return to level 1.

UP ▲ key: In the programming menu, you may scroll around the different levels, or during the setting of a parameter, change its value.

DOWN ▼ key: In the programming menu, you may scroll around the different levels, or during the setting of a parameter, change its value.

SET key: Allows the displayed value to be changed (overheating, suction pressure, expansion valve opening or temperature) (only if the $dñ$ parameter = 0).

The programming menu allows you to move around the different levels and accept changes. Pressing it for 5 seconds exits the programming menu.

Display

The value displayed is set via the $dñ$ parameter. By default, it displays the overheating value.

Adjustment of parameters

Using the programming menu, you will be able to configure the various parameters in order to adapt the controller's operation to the needs of its installation.

In order to access the programming menu, press the **PRG** key for 5 seconds, or until the message "Pud" appears on the display. Using the ▲ and ▼ keys enter the password (programmed into the $P55$ parameter) and press **SET**. Once entered correctly, the password will not be requested again for 30 minutes.

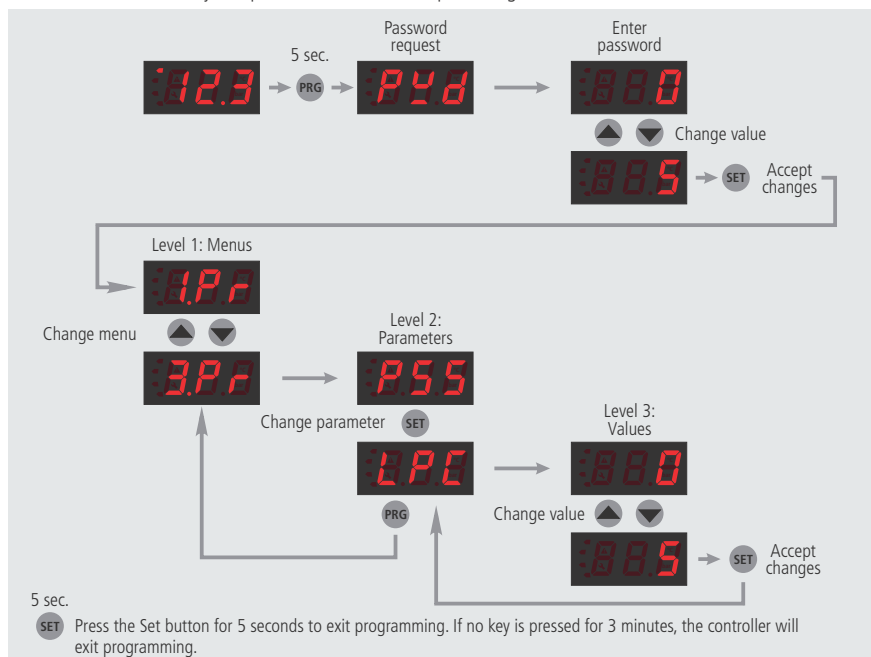

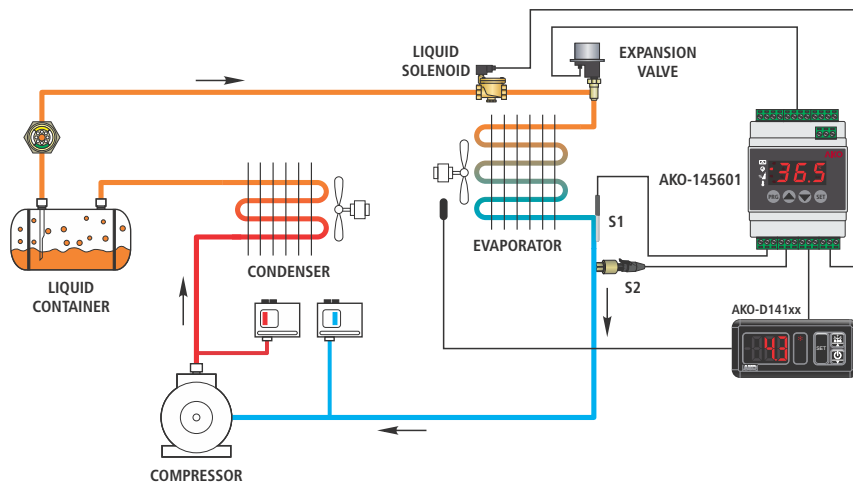

Regulation

The controller regulates the opening of the expansion valve according to the temperature and pressure readings obtained by probes 1 and 2, and according to the demand for controlled cooling by an external element (ON / OFF input).

If there is demand for cooling (ON / OFF input active) the controller opens the liquid solenoid and regulates the opening of the expansion valve in order to obtain the overheating shown on the **Sh** parameter.

When the cooling demand is completed, the controller closes the liquid solenoid and expansion valve, displaying the **StP** message on screen.

The **or** and **ort** parameters define the behaviour of the expansion valve during start up.

- or**: Defines the opening degree of the valve at the moment when the controller is started up. We recommend that this value is as close as possible to the opening work value, in order to ensure smooth control. If continuous stop and starts are detected for the compressor, or if there is a return of liquid, lower the initial opening value. If excessively low pressures are detected during start up, increase the initial opening value.
- ort**: Defines the duration in seconds of the initial valve opening (defined in **or**). Once this time has elapsed, the controller will begin to regulate the valve automatically.

The regulation parameters (**Pro**, **int**, **dEr**), determine how opening of the expansion valve is modified in light of the temperature and pressure variations detected.

- Pro**: The proportional gain determines how the valve opening varies for each level of overheating variation. If set to 3%, the valve opening varies 3% per 1.0K of overheating.
If the opening is too unstable, lower the gain value. If the opening is too stable, increase the gain value.
- int**: Determines the controller response speed according to the degree of deviation between the current overheating value and the set point (**Sh**). The lower the value, the greater the response speed and, therefore, the greater the oscillations are before getting to the set point.
- dEr**: Determines the controller response speed to sudden changes in pressure/temperature. The higher the value, the faster the corrective action will be, but oscillations will also increase before reaching the set point.

Alarms

The alarms alert the user and stop regulation (closing the expansion valve) if determined values of pressure, overheating or temperature are reached. These values are defined using the following parameters:

$L5\bar{n}$: Lower overheating alarm	$h5\bar{n}$: Maximum overheating alarm
$L\bar{P}\bar{n}$: Lower pressure alarm in probe 2	$\bar{n}P\bar{n}$: Maximum pressure alarm in probe 2
$FP\bar{n}$: Ice alarm in evaporator	

For every alarm 4 options must be configured:

Activation type

- **Disabled:** The alarm is not activated.
- **Automatic reset:** The regulation restarts when the deactivation value of the alarm is reached.
- **Manual reset:** In order for the regulation to restart, it is necessary to press the **PRG** button twice.

Turn-on value

If this value is reached, the regulation stops and the equipment displays a message on screen.

Turn-on delay time

Defines the delay time between when the turn-on value is reached and the alarm activates.

Deactivation value

Defines the value at which the alarm is no longer displayed and the machine returns to standard regulation (if automatic reset has been set up).

Pressure Probe (S2)

The measuring range of the pressure probe set in the factory, on the probe model provided (**AKO 15571**), should only be changed if a different probe is installed. It should only be configured by qualified staff.

PSh : Maximum range of pressure probe.

PSL : Lower range of pressure probe.

The PSo parameter allows you to vary the value read by the pressure probe (offset). It is used to compensate for reading errors when the probe can not be positioned in the correct place.

Temperature probe (S1)

The TSo parameter allows you to vary the value read by the temperature probe (offset). It is used to compensate for reading errors when the probe can not be positioned in the correct place.



If probe readings have continuous fluctuations, a reading delay may be set as a filter in order to stabilise the reading. This delay is configured using the FE parameter and affects probes S1 and S2.

Expansion valve

You can customise the behaviour of the expansion valve using the following parameters:

UEr : Using this parameter, you may limit the opening speed of the expansion valve

UrL / UrL : They allow the maximum and lower opening degrees of the expansion valve to be limited.

Eor : This parameter allows a certain opening degree of the expansion valve to be set. While this option is active, the opening will remain fixed (unregulated) and the LED will remain manually lit up (page 7).

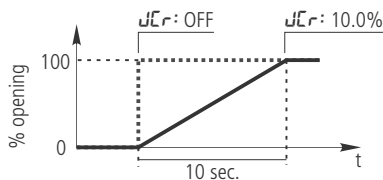

Initial parameters

Using the *ini* parameter, all of the parameters can be reset to their default values. For this to take effect, select the parameter and enter the password using the ▲ and ▼ keys. Press **SET** to reset the controller to its factory parameters.

6.- Table of parameters

The equipment's operation functions are divided into 3 different groups.

The **Def.** column indicates the default parameters set in the factory. Temperature values are expressed in °C. (Equivalent temperature in °F) and the pressure values in bar (equivalent pressure in psi).

Level 1	Level 2	GROUP 1				
		Description	Value	Min.	Def.	Max.
iPr	Sh	Overheating set point	(K)	3.5	10	30
	or	Initial opening for valve start up	(%)	0	50	100
	ort	Duration of initial start up opening	(Sec.)	0	5	300
	Pro	Proportional gain		0.1	3	99.9
	int	Integral time	(Sec.)	0	120	999
	dEr	Derivative time	(Sec.)	0	30	999
	L5n	Lower overheating alarm 0: Deactivated 1: Automatic reset 2: Manual reset		0	1	2
	L5S	Lower overheating alarm activation value	(K)	0.5	3	30
	L5t	Lower overheating alarm turn-on delay time	(Sec.)	1	15	300
	L5C	Lower overheating alarm deactivation time	(K)	1	3	30.5
	nPn	Maximum pressure alarm in probe 2 0: Deactivated 1: Automatic reset 2: Manual reset		0	1	2
	nPS	Maximum pressure alarm activation value	(bar/psi)	-999	9	999
	nPt	Maximum pressure alarm turn-on delay time	(Min.)	1	1	15
	nPC	Maximum pressure alarm deactivation time	(bar/psi)	-999	8	999
	h5n	Maximum overheating alarm 0: Deactivated 1: Automatic reset 2: Manual reset		0	0	2
	h5S	Maximum overheating alarm activation value	(K)	10.0	30	40.0
	h5t	Maximum overheating alarm turn-on delay time	(Min.)	1	3	600
	h5C	Maximum overheating alarm deactivation time	(K)	7.0	27	37.0
	FPn	Freeze alarm 0: Deactivated 1: Automatic reset 2: Manual reset		0	0	2
	FPS	Maximum freeze alarm activation value	(°C/°F)	-100	0	200
	FPt	Freeze alarm turn-on delay time	(Sec.)	5	30	200
	FPC	Maximum freeze alarm deactivation time	(°C/°F)	-100	3	200
	Lpn	Lower pressure alarm in probe 2 0: Deactivated 1: Automatic reset 2: Manual reset		0	0	2
	LPS	Lower pressure alarm activation value	(bar/psi)	-999	0	999
	LPt	Lower pressure alarm turn-on delay time	(Sec.)	5	5	200
	LPC	Lower pressure alarm deactivation time	(bar/psi)	0	0.3	999

Level 1	Level 2	GROUP 2				
		Description	Value	Min.	Def.	Max.
2Pr	PU	Pressure units 0: Bar 1: Psi		0	0	1
	tu	Temperature units 0: °C 1: °F		0	0	1
	En	Selection of expansion valve model connected 1: Danfoss ETS 12.5 / 25B 2: Danfoss ETS 50B 3: Danfoss ETS 100B 4: Danfoss ETS 250 5: Danfoss ETS 400 6: Alco EX4 7: Alco EX5 8: Alco EX6 9: Alco EX7 10: Alco EX8 (330 step/sec) 11: Alco EX8 (500 step/sec) 12: Sporlan SEI 0.5~11 13: Sporlan SEI 1.5~20 14: Sporlan SEI 30 15: Sporlan SEI 100 16: Sporlan SEI 175 17: Carel E2V		1	1	17
	ESL	Total steps for expansion valve*		0	262	999
	dSP	Expansion valve speed*		0	250	999
		GROUP 3				
		Description	Value	Min.	Def.	Max.
3Pr	PSS	Parameter access password		0	5	999
	rFE	Type of refrigerant gas used: 2: R-404A 3: R-407C 4: R-410A 5: R-717 6: R-23 7: R-507C 8: R-HFO1234ze 9: R-744 10: R-407A 11: R-407F 12: R-507A 13: R-245F	0: R-22 1: R-134A	0	1	13
	PSH	Pressure probe range (Maximum)	(bar/psi)	-999	15	999
	PSL	Pressure probe range (Lower)	(bar/psi)	-999	-1	999
	PSa	Pressure probe calibration (S2)	(bar/psi)	-19.9	0	19.9
	ESa	Pressure probe calibration (S1)	(°C)	-19.9	0	19.9
	uCr	Expansion valve opening speed limit	(%)	0.1	OFF	99.9
	UrL	Maximum expansion valve opening limit	(%)	0	100	100
	LrL	Lower expansion valve opening limit	(%)	0	0	100
	FE	Reading delay for probes (S1 and S2)	(Sec.)	0.1	1	10.0
	Eor	Lower expansion valve forced opening value	(%)	0.0	OFF	100
	dñ	Display mode: 0: Displays options 1 to 4 sequentially 1: Overheating value (°K) 2: Suction pressure value (Probe 2) 3: Valve opening (%) 4: Temperature value (Probe 1) 5: Overheating set point		0	1	5
	Eid	Communication direction		1	1	128
	ESP	Communication speed	(BPSx100)	48	96	384
	ini	Initial settings (enter password and press SET)		0	0	999

* The **ESL** and **dSP** parameters are adjusted automatically when the expansion valve model is selected. They should only be changed by qualified staff. **AKO** is not responsible for any damage that may be inflicted on the installation.

7.- Technical specifications

Controller AKO-145601

Power supply	24 V~ +10% / -15%, 50/60 Hz
Consumption including expansion valve	1A
Output for expansion valve	Valves with a bipolar stepper motor
Compatibility with expansion valves.....	(see page 3)
Maximum consumption of expansion valve.....	700 mA
Opening control precision.....	1/1000 (0.0 to 100.0 %)
Working ambient temperature	-10 to 50 °C, moisture <90 %
Storage ambient temperature	-20 to 60 °C, moisture <90 %
Relay solenoid valve	(EN60730-1: 2(2) A 250 V~ SPST)
No. of relay operations	EN60730-1: 100.000 operations
Compatibility with refrigerant gases.....	(see page 3)
Communications	MODBUS RTU / ASCII (Rs485)
Terminals	Screw-on, up to 2.5 mm ²
Dimensions	(Vsee page 4)
Assembly.....	DIN rail
Maximum voltage in the SELV circuits.....	20 V
Protection degree	IP2X
Connections	Terminal to screw for cables with a section of up to 2.5 mm ²
Control device classification: Built-in assembly, with Type 1.B automatic operation action feature, for use in clean situations, logical support (Software) class A and continuous operation. Degree of contamination 2 acc. to UNE-EN 60730-1.	
Double power input insulation, secondary circuit and relay output.	
Rated pulse voltage	2500V
Pressure ball test temperature Accessible parts	75 °C
Parts that position active elements.....	125 °C
Voltage and current declared by the EMC tests.....	207V, 17 mA
Radio interference suppression test current.....	270 mA

Pressure probe AKO-15571 / AKO-15572

Power supply	5 Vcc \pm 5%
Output.....	DC 0.5 to 4.5 V, ratiometric
Protection degree.....	IP65
Measuring range AKO-15571	-1 to 15 bar
AKO-15572	-1 to 25 bar
Precision	\pm 0.25%
Maximum pressure supported.....	1.5 times the maximum reading range
Maximum peak pressure	3 times the maximum reading range
Working ambient temperature.....	-40 to 80 °C
Wiring Black	Common
Red.....	+5V
Green.....	Signal
Length of cable	2 m

Temperature probe AKO-15606

Type of sensor.....	Pt1000
Protection degree.....	IP67
Measuring range.....	-100 to 120 °C
Precision	\pm 0.3 °C to 25 °C
Length of cable	2 m (0.5 mm ²)
Response time.....	1 second

Transformador AKO-80077

Input.....	115/230 V~ 50 / 60 Hz
Output	24 V~ 50 / 60 Hz
Assembly.....	DIN rail

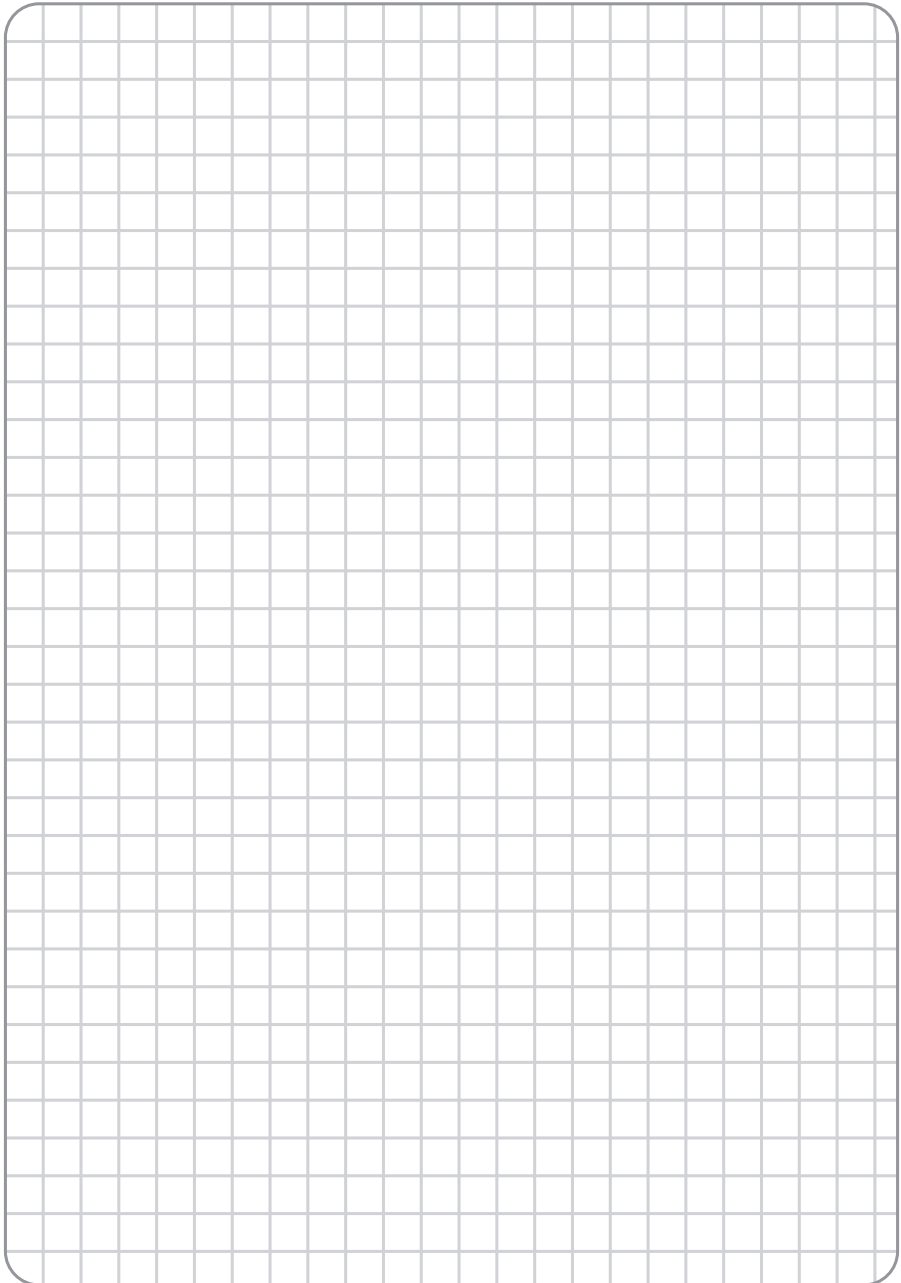

AKO ELECTROMECÁNICA, S.A.L.

Avda. Roquetes, 30-38

08812 • Sant Pere de Ribes.

Barcelona • Spain.

Tel.: +34 902 333 145

Fax: +34 938 934 054

www.ako.com

351456002 REV.02 2018